



Mobile GPUs

Varun Sampath
University of Pennsylvania
CIS 565 - Spring 2012

Agenda

- SoCs
- Case Studies
 - NVIDIA Tegra 2, Tegra 3
 - Imagination Technologies' PowerVR SGX Series5XT
 - Apple iPad (2012)
- Future
- Note about sources

What is an SoC?

- System-on-a-Chip
 - CPU, GPU, DSP, I/O
 - Single-chip solution
- Top mobile SoC vendors:
 - Qualcomm, Apple, TI, Samsung, NVIDIA
- Advantages of using SoCs?
- Disadvantages?
- We will see all consumer chips converge to SoCs

Mobile SoC Market Share 2011

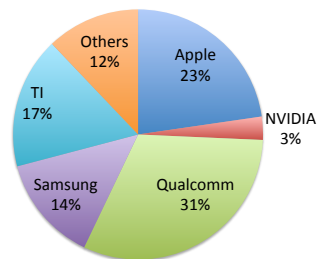

Market Share Data from [PC Perspective](#)

What is an SoC?

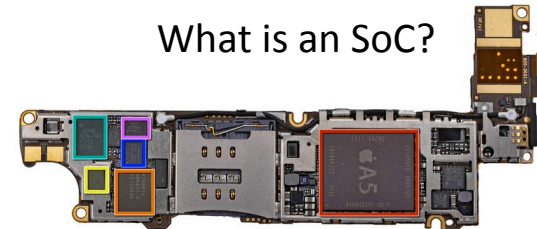

- Apple A5 Dual-core Processor (more on this later)
- Qualcomm RTR8605 Multi-band/mode RF Transceiver. [Chipworks](#) has provided us with a die photo.
- Skyworks 77464-20 Load-Insensitive Power Amplifier (LIPA®) module developed for WCDMA applications
- Avago ACPM-7181 Power Amplifier
- TriQuint TQM9M9030 surface acoustic wave (SAW) filter
- TriQuint TQM666052 PA-Duplexer Module

Image from [Fixit](#)

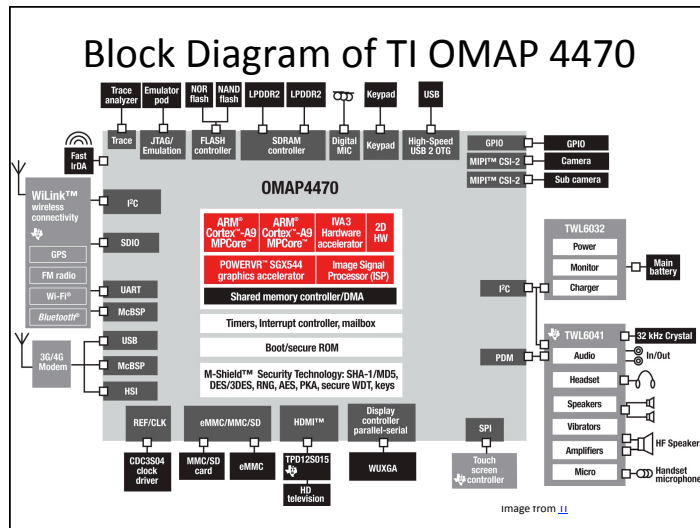

- ### Brief Discussion of ARM
- RISC CPU vendor that currently dominates mobile
 - Mobile Designs: Cortex-A8, A9, A15
 - Fabless Designer
 - Core Design Licensees
 - Architecture Licensees
 - Qualcomm Scorpion/Krait
 - NVIDIA

- ### The Constraints of Mobile
- Energy
 - Cell phone battery capacity of 5-7 Wh (tablets 20-40 Wh)
 - How much energy can our chips consume?
 - Area
 - PCB size constraints
 - Cooling constraints

Some Energy Numbers

Power Consumption Comparison		
	Apple iPhone 4 (AT&T)	Apple iPhone 4S (AT&T)
Idle	0.7W	0.7W
Launch Safari	0.9W	0.9W
Load AnandTech.com	1.0W	1.1W
Maps (Determine Current Location via GPS/WiFi)	1.3W	1.4W

Power Consumption Comparison		
	Apple iPhone 4 (AT&T)	Apple iPhone 4S (AT&T)
Launch Infinity Blade	2.2W	2.6W
Infinity Blade (Opening Scene, Steady State)	2.0W	2.2W

Data from [AnandTech](#).

Some Contributors to Switching Energy

- Off-chip Interconnect (to DRAM)
 - Bandwidth is expensive
 - Minimize reasons to fire up memory bus
- High frequencies
 - Requires increased voltages

Some Theoretical Performance Numbers

	Apple iPad 2	ASUS Transformer Prime	Some Nice Desktop
CPU	A5 @ 1GHz	Tegra 3 @ 1.4GHz	Sandy Bridge @ 3.4GHz
GPU	POWERVR SGX543MP2 @ 250MHz	Mobile GeForce @ 500MHz	GTX680 @ 1GHz
Memory Interface	64-bit @ (maybe) 800MHz = 6.4GB/s	32-bit	256-bit @ 6GHz = 192GB/s
GPU GFLOPS	16 GFLOPS	12 GFLOPS	3 TFLOPS

Mobile Data from [AnandTech](#)
GTX680 Specs from [Newegg](#)

GeForce GPU in NVIDIA Tegra 2

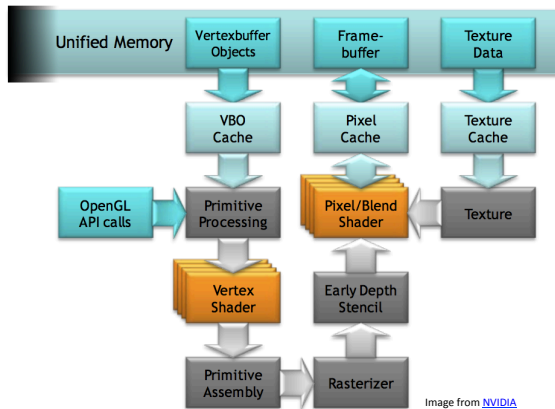

Tegra 2 Mobile GeForce

- Separate vertex and pixel shaders
 - 4 of each, each capable of 1 multiply-add /clock
- Pixel, texture, vertex, and attribute caches
 - Reduce memory transactions
 - Pixel cache useful for UI components
- Memory controller optimizations
 - Arbitrate between CPU & GPU requests
 - Reorder requests to limit bank switching

NVIDIA Tegra 3 (Kal-EI)

- Expanded Mobile GeForce
 - 4 vertex and 8 pixel shaders
- 4-PLUS-1 architecture

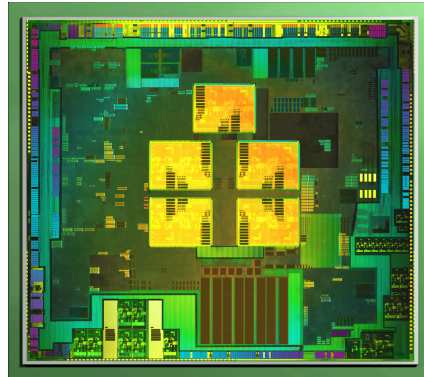
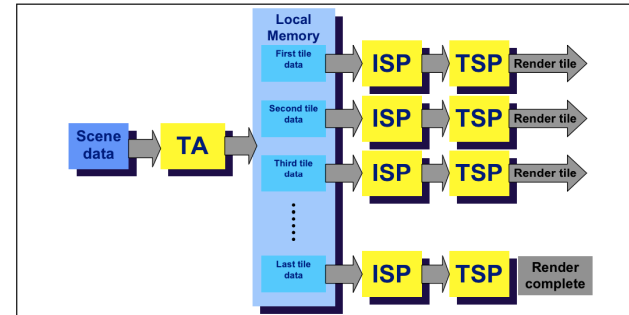

Image from [AnandTech](#)

PowerVR SGX



- TA (Tile Accelerator) – store scene data and split up screen into tiles
- ISP (Image Synthesis Processor) – perform Hidden Surface Removal with z-testing
- TSP (Texture and Shading Processor) – run pixel shader

Image from [imgTec](#)

PowerVR SGX Series5XT

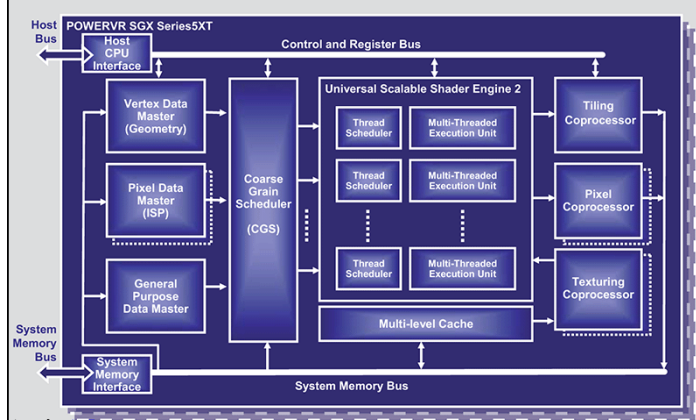

Image from [imgTec](#)

Summarizing PowerVR SGX Series5XT

- Used in Apple A5, A5X
- Unified shader architecture (called USSE2)
- Tile based deferred rendering (TBDR)
 - Will cover in more detail next week
- Multi-core architecture

Mobile GPU Families

- Qualcomm Adreno
 - Unified shaders, 4-wide SIMD
 - immediate mode with early-z
- Imagination Technologies' PowerVR SGX Series5XT
 - Unified shaders, 4-wide SIMD
 - Tile based deferred rendering
- NVIDIA Mobile GeForce
 - Separate vertex (4) & pixel (8/12) shaders , scalar
 - immediate mode with early-z
- ARM Mali
 - Separate vertex (1) & pixel (4) shaders , 4/2-wide SIMD
 - immediate mode with early-z

Analysis by [AnandTech](#)

Demands for Mobile

- Higher screen resolutions
 - Requires more memory bandwidth
 - Pixel count growing higher than geometry?
- Longer battery life
- Higher quality mobile gaming

Case Study: the new iPad

- Screen resolution of 2048x1536
 - Quadruple the pixels of previous 1024x768 version
 - Higher than nearly all desktop and laptop displays
- Battery life approximately equal to previous version
- Gaming performance?

iPad Gaming Performance

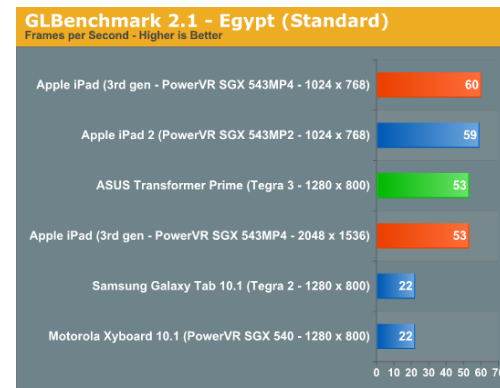
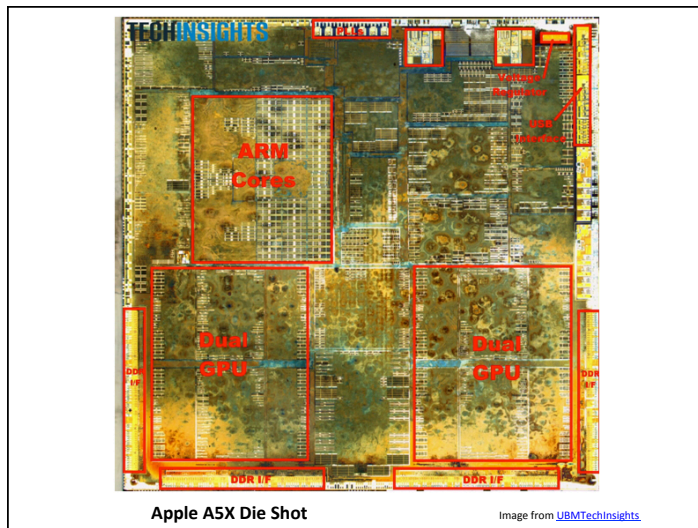

Image from [AnandTech](#)



Apple iPad Statistics

	Apple iPad 2	Apple iPad (2012)	11" Apple MBA
CPU	A5 @ 1GHz	A5X @ 1GHz	Sandy Bridge @ 1.8GHz
GPU	POWERVR SGX543MP2 @ 250MHz	POWERVR SGX543MP4 @ 250MHz	Sandy Bridge IGP @ 350MHz/1.2GHz
Memory Interface	64-bit @ 800MHz = 6.4GB/s	128-bit (for GPU)	128-bit @ 1.3GHz = 20.8GB/s
Die Size	122mm ²	163mm²	149mm ²
Battery Size	25Wh	42.5Wh	35Wh



Data and Image from [AnandTech](#)

What will the future bring?

- GPU Compute
 - PowerVR SGX Series5XT OpenCL capable, but no drivers
 - Could do compute the [old-fashioned way](#) with GLSL
 - Direct3D 11 means Compute Shader support
- PowerVR Series6 [press release](#) suggests 100-1000 GFLOPS
- Kepler-based GPU coming to a [super phone](#) near you?